

Pride of the Eastside



2023 Submission James D. MacConnell Award

**Eastside Memorial Early College
High School**

Austin ISD, Austin, Texas



Executive Summary

Through a strong vision of academic excellence, multiculturalism, and community connectivity, the new Eastside Early College High School and the International School is designed to **honor the past, excel in the present and positively impact the future**. Key to this vision is the relocation of the schools to the site of the Original L.C. Anderson High School, which had an 82-year history of serving the African American Community in East Austin with excellence in academics, fine arts, career preparation, and athletics. In 1971, it was **ordered to be closed by a federal court as part of desegregation**, which shuttered the lifeblood of the community and scattered its students across the city. Sitting vacant for decades, the school became structurally condemned, no longer symbolizing the hope of education. Instead, it came to represent the systemic racial injustice impacting and oppressing the community.

The new school rebuilds the African American community heritage through historic reconstruction, alumni gallery, and graphic history walls. Out of the **foundation of the past, the new campus rises upward** to uplift the students of Eastside Early College High School and International High Schools. The design approach was deeply collaborative to ensure the campus **echoes the stories of perseverance** of all three schools while providing future-focused programming and creating opportunities for **pathways out of poverty**. The new campus stands as a landmark against social injustice, racial division, and economic oppression to embody a new hub of community as the **Pride of the Eastside**.

Scope & Budget

Client: Austin Independent School District

Location: Austin, Texas

Project Type: New Construction

Completion Date: August 2021

Construction Cost: \$67,531,146.00

Grades: 9-12

Student Capacity: 800

Current Enrollment: 637

Building Area: 173,000 S.F.

Site Area: 19.20 Acres

Sustainability: Pursuing LEED Silver

School & Community Engagement

LIST OF COMMUNITY STAKEHOLDERS

- Eastside ECHS -Administration, Faculty, Staff, Parents Community, and students
- International HS - Administration, Faculty, Staff, Parents Community, and students
- Original L.C. Anderson HS Alumni – Classes of 1964-1971
- Austin Community College
- Rosewood Neighborhood Association
- Blackshear Neighborhood Association
- Washington Caver Museum and Cultural Center
- Texas Historical Commission
- Austin History Center
- Austin ISD Board Facilities and Construction

SCHOOL AND COMMUNITY HISTORY

The community of Eastside was brought up on the other side of the redline in Austin. Upon court ordered desegregation in 1971, the community of L.C. Anderson HS was evicted from its beloved high school civic center to watch it erode for decades. Eastside ECHS had been relocated and shuttered multiple times and faced the same economic disadvantages. The International school brings in students from all over with no English language skills. All three groups were looking for a community of their own and pathways out of poverty. Both high schools and the alumni were seeking a project that provided cultural identity, community respect, and academic excellence.

- Listening to each campus's history with empathy
- Ideating on what is important in order to tell the story
- Large group discussions on how to become a community hub
- Small group discussions on academic excellence
- Alumni input at their reunion
- Student voices to fit today's needs
- Neighborhood association input for broad community support
- Coordination with Carver Museum for legacy gallery
- Research meetings at the Austin History Center

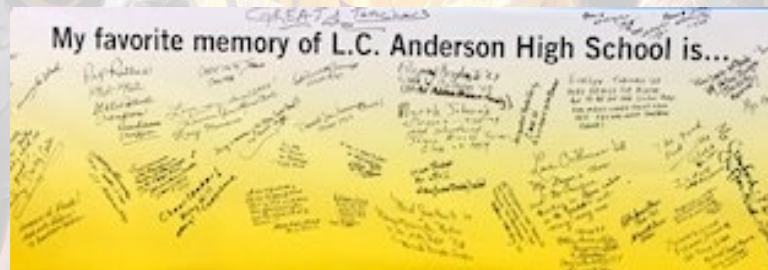

L.C. Anderson Alumni Workshops



Community Engagements



Student Workshops



Faculty Workshops

— Challenges into Opportunities

CHALLENGE: Identity

One of the biggest challenges from the onset of the project was how to design a building which would embody the identity of three separate High Schools.

- **L.C. Anderson H.S.** – A shuttered school with a rich history and active alumni group.
- **Eastside Early College** – School struggling to find a home with an economically depressed and marginalized student population.
- **International School** – E.S.L. school with a global student body.

OPPORTUNITY

Through multiple engagements and stakeholder workshops, what developed was a rich branding opportunity that helped unite three separate entities into one. By experience mapping of the past (Anderson), the present (Eastside and International), and the future (all three unified), a vibrant and unified messaging resonates throughout the new school. The pillar of the messaging was based on the motto: ***It is what is inside us, our struggles and our victories, that unite us.***

GRAPHIC SYSTEM AND MESSAGING

ANDERSON
EASTSIDE
INTERNATIONAL

ANDERSON
EASTSIDE
INTERNATIONAL

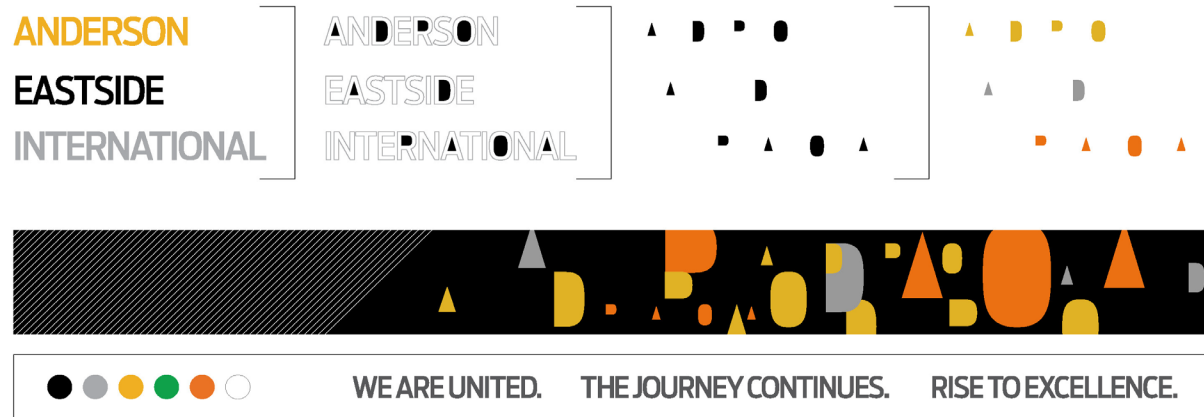

WE ARE UNITED. THE JOURNEY CONTINUES. RISE TO EXCELLENCE.

Nodes to experience

- Past.
- Present.
- Future.

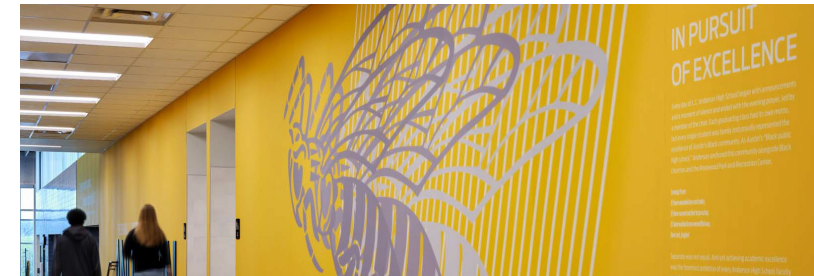
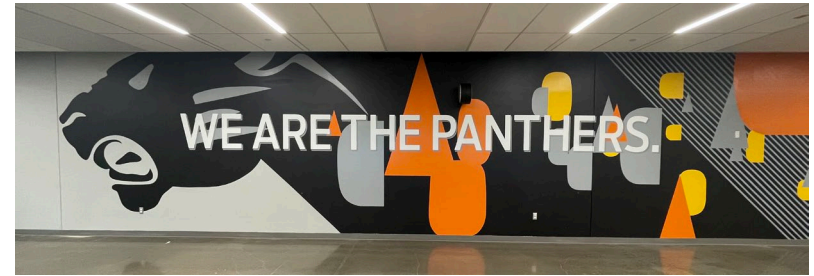
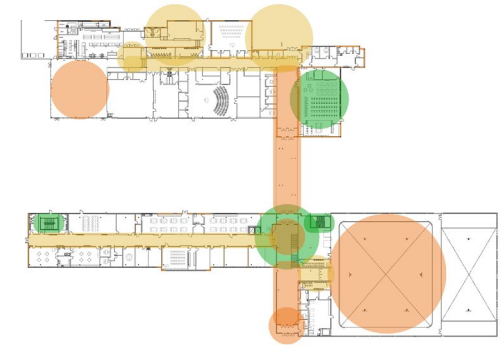

— Challenges into Opportunities

CHALLENGE: Structure

- The LC Anderson Alumni wanted to restore their community and legacy by having their old school building preserved although major parts of it were structurally condemned.
- The Eastside and International schools wanted a new space equitable to other newer district high schools with future ready learning spaces and equity with other district campuses' education specification.

These two challenges were often in conflict with each other and required careful negotiations to balance the needs of all.

OPPORTUNITY

We worked with the Texas Historical Commission and the alumni group and agreed that certain portions of the existing school would be reconstructed and act as the base grounding element for the new building.

The new areas of the campus fully meet the equity needs of Eastside and International and are outfitted as a modern school. Reuse of historic areas shifted uses to meet needs of size such as the old cafeteria becoming the new library and old band hall becoming the new choir.

LIMIT OF RECONSTRUCTION PER HISTORIC AGREEMENT

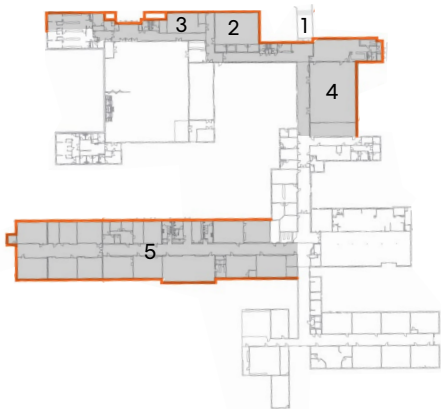

1. Front entry
2. Band Hall as new Choir
3. Choir room as new community room
4. Cafetorium as new library
5. Original academic wing



Original L.C. Anderson main entry



Original L.C. Anderson interior



Historic entry of new build

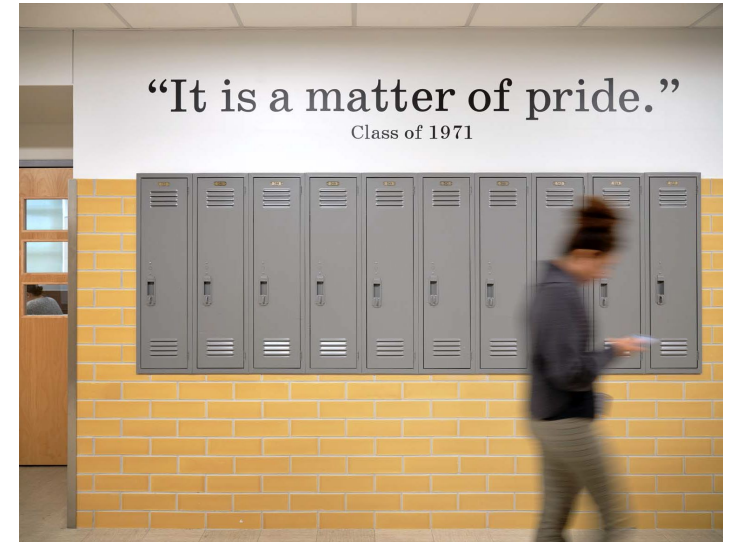

Reused lockers, ceramic tile and other materials to preserve history and culture of the Original L.C. Anderson H.S.

— Value of Process and Project

PRIDE OF THE EASTSIDE

For 50 years the derelict building left behind was a constant reminder of social injustices the L.C Anderson community endured. The issue was not lack of support for the long-term gains of desegregation, but rather that the closure process stripped the African American community of their identity and community hub. They were transported across town, bullied, and abused. Their voices were distributed so this that they were no longer heard.

Throughout the community engagement process, we ensured all voices were heard. There were countless stories of a marginalized community overcoming hardships to become the backbone of the community effort to bring back **THE PRIDE OF THE EASTSIDE**.

The school represents the themes of perseverance, excellence and pride that become the foundation for the schools' design including branding and the architectural forms rising out of the old school and into the skyline.

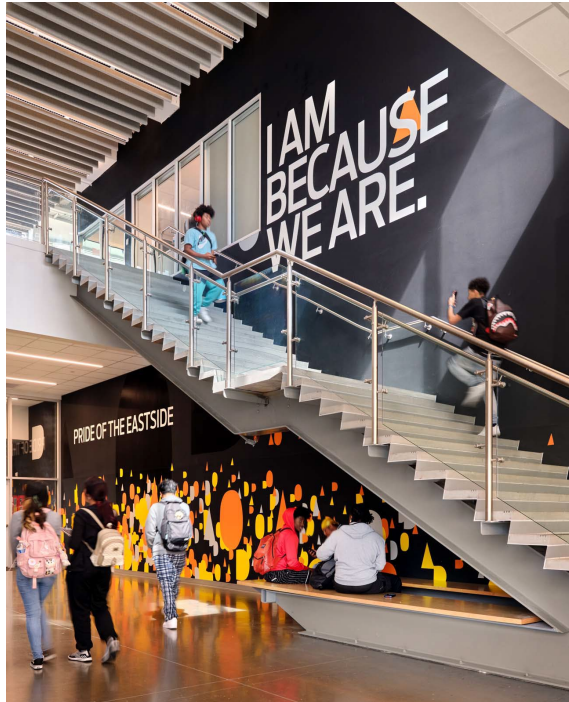

— Partnerships and Assets

PRESERVING LEGACY: CARVER MUSEUM



The original L.C. Anderson High School Alumni, Austin ISD, and Perkins&Will worked closely with the Carver Museum and the Austin History Center to acquire photography and visualize a primarily oral history, which is displayed in the graphics at the interior of the campus. The old choir room now functions as a community room which proudly displays the rich history of the community and project site. At its core, the school's story is one of inclusion and equity.

OPPORTUNITIES FOR THE FUTURE: AUSTIN COMMUNITY COLLEGE

As an Early College High School, the partnership and proximity of Austin Community College is a real asset for students realizing college credits at no cost. Austin Community College worked with Perkins&Will and the faculty to design the early college programs, spaces, and equipment.

Sitting high on the hill, the campus has a pathway to college and a big view on par with the aspirations of the central business district and medical center in Austin.



Education Environment Design

The educational vision of the school was to really **heighten the opportunities for career and college readiness**. Eastside ECHS and International HS wanted to work hand in hand with Austin Community College to prepare students and help them visualize themselves in a college setting. Everything from curriculum writing, shared professors, and shared prerequisites were aligned. The college and career focus topics were selected **based upon the workforce needs of the community**: health science, engineering, audiovisual and business.

The educational vision supported project-based learning with collaboration areas in view of classrooms, enclosed small group areas, and a technology rich atmosphere.



— Career and College Ready



NURSING LAB

Nursing lab is designed for all the skills needed for a 2 year LVN program including:

- Labor and delivery
- Neonatal care
- Trauma care
- ICU care



ALLIED HEALTH SCIENCE LAB

This area is set up to facilitate a sampler course with highly flexible spaces including:

- Veterinary medicine
- Dental
- Emergency Medical Services
- Pharmacy tech
- Philbotomy



Historic portion of building with high bay ceilings functions as early college engineering and maker spaces with direct access outside.



Informal library with soft seating for a higher education look and feel is configured on the historic cafetorium stage.



High levels of transparency between interior spaces to allow students project-based learning opportunities.

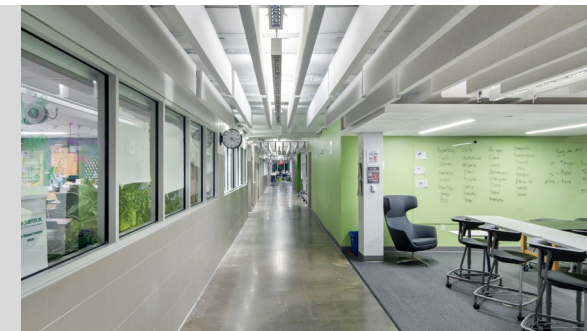

— Adaptable and Flexible



Breakout collaboration and small group areas are arranged for English language learning with high acoustic properties in a variety of groupings to help International HS assimilate.



Interior glazing in science labs and classrooms provides a strong connection for interdisciplinary project work and easy supervision of flex spaces in open corridor pictured page left.



The courtyard is a collaborative outdoor learning space direct connections to outdoor art, engineering robotics raceway, special education sensory garden, band performance, stage to black box and outdoor dining.



Classrooms were designed for sustainable heat and glare reduction with views to the city. Classrooms have fully mobile technology, operable partitions and flexible furniture to meet all needs.

Physical Environment Design

The physical environment **brings together the past and the present** by melding the historic materials and mid-century aesthetic with the openness of a contemporary learning environment.

The **new academic tower rises above the city skyline** as a landmark of the Eastside – a testament to the history of perseverance of the community.



— Site and Environment



- 1. BUILDING 1
- 2. BUILDING 2
- 3. GYMNASIUM
- 4. HISTORIC ENTRY
- 5. BUS PICK-UP AND DROP-OFF
- 6. COURTYARD/OUTDOOR LEARNING
- 7. PLAYING FIELDS
- 8. PARKING
- 9. WELLNESS WALK
- 10. AUSTIN COMMUNITY COLLEGE

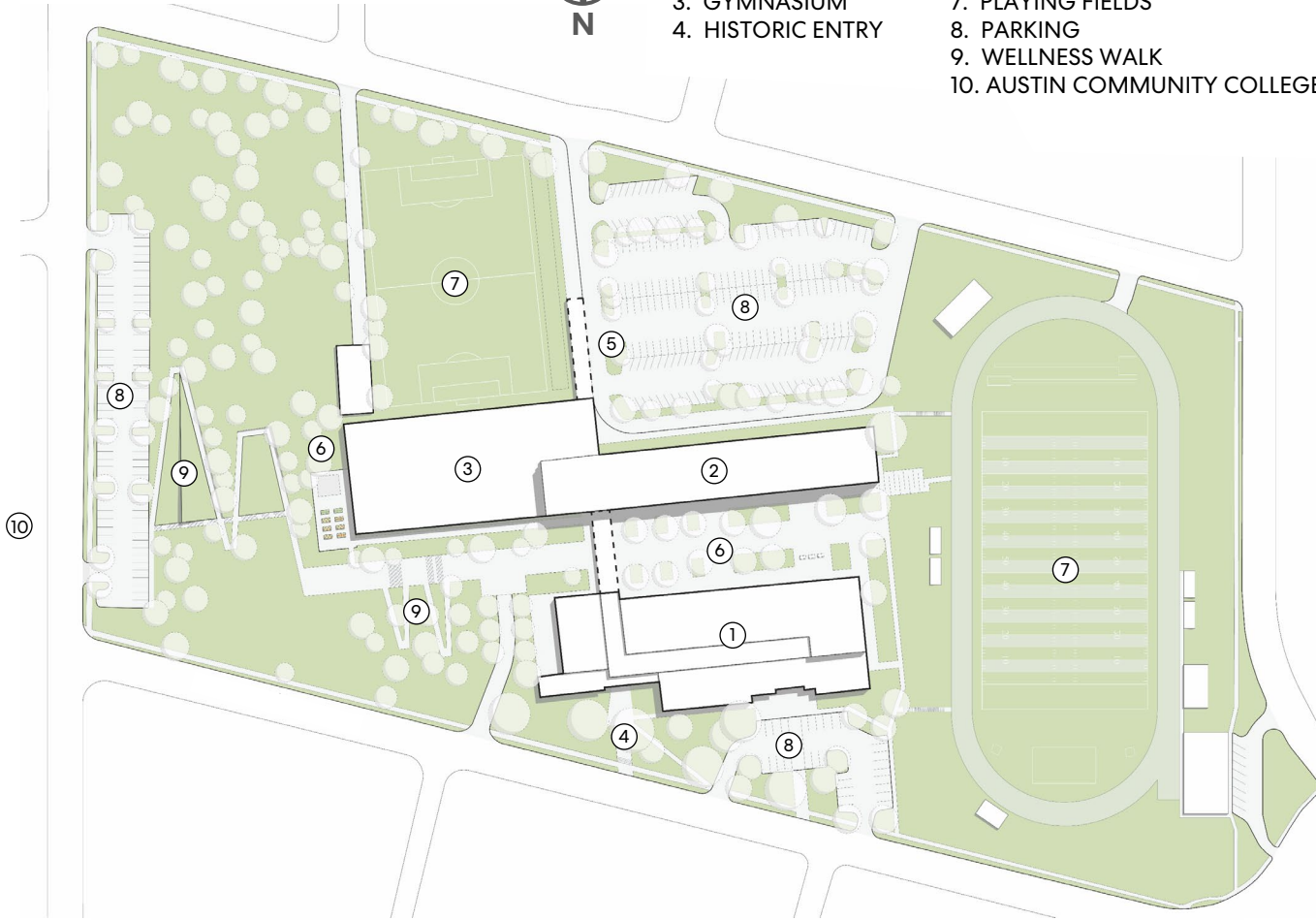

Sitting at the top of the hill, the campus overlooks views of downtown in both the tower and the outdoor learning spaces. The open courtyard between the buildings is designed for outdoor dining, band practice, art, engineering, and special education sensory gardens.

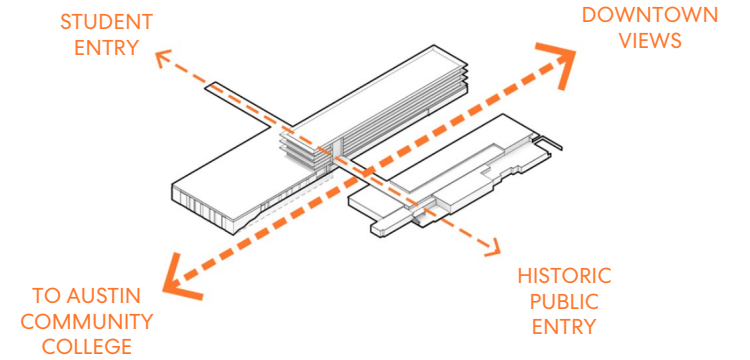

The Site posed both opportunities and challenges. The top of the hill has a fault line, the side of the hill has a head scarp, and the footprint of the historic rebuild zone drove the site plan.

The outdoor “wellness walk” down the hill provides a physical fitness amenity in the connection to the community college to support Early College programs. The multi-building campus’ collegiate style further emphasizes its focus on preparing students for college and allied health careers. Parking at the low end of the hill allows ease of access to ACC.

SITE SECTION THROUGH COURTYARD

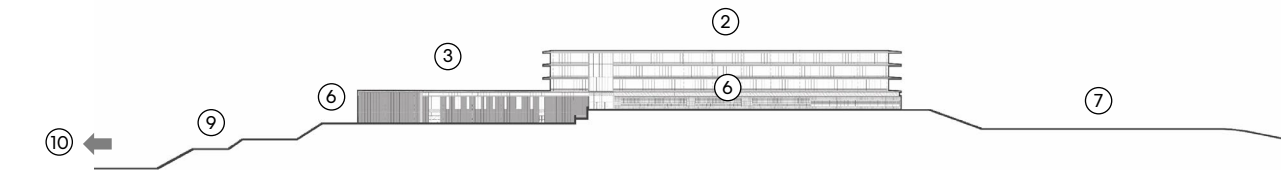

— Historic and Contemporary

The design of the school honors alumni and preserves the legacy of the original L.C. Anderson High School by reconstructing significant elements of the original building with the original forms and materials, such as the 1950's horizontal feel of the original front of the school. The original red brick and mid-century aesthetic of the existing buildings are gracefully separated from the modern glass and concrete forms with an architectural reveal which presents a cohesive composition yet clearly delineates the old and the new. New forms are in neutral colors of charcoal brick and light plaster that reinforces the horizontal feel.

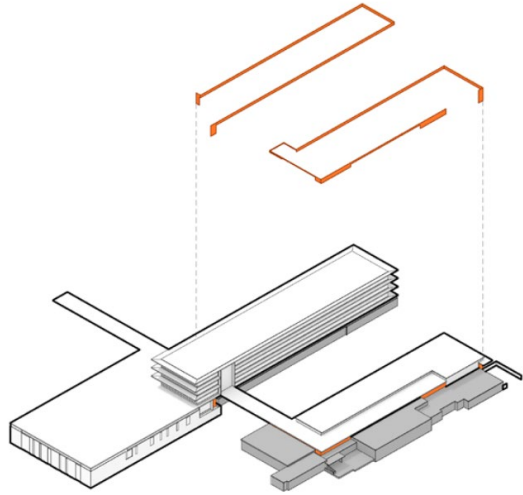

BUILDING REVEAL



HISTORIC

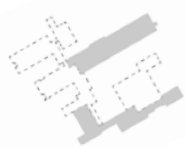

DEMO

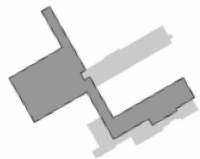

NEW

NEW: CONCRETE AND WINDOWS WITH SPARSE VERTICAL MULLIONS

REVEAL: DARK GRAY METAL PANEL

HISTORIC: BRICK, STUCCO, GLASS BLOCK, AND WINDOWS WITH DENSE GRID MULLION PATTERN



— Community Context



With the history of the community using this site for a place to exercise and gathering it was vitally important to maintain openness to the community. The gymnasium is positioned with a separate entrance that allows for ease of community use during off hours. The Yellow Jacket Conference Room in the historic portion of the building was previously a choir room but now functions as dedicated community room.

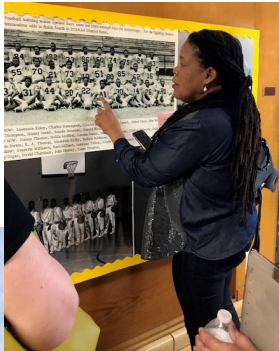

The existing track and field at Yellow Jacket Stadium have been maintained over the decades by an Anderson Alum turned Cowboys football star, Thomas “Hollywood” Henderson. The original locker room, track, and field are preserved in place and fully open for use continuing the tradition of the site acting as a hub of the community.

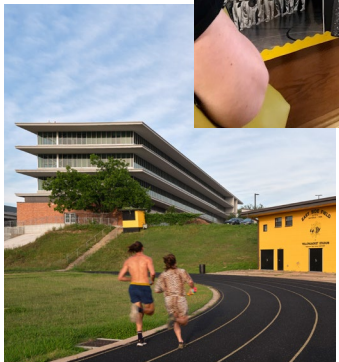

The stories of the Legacy of Anderson continue to be told today as the images and artifacts are gathered for display in the gallery at the Yellow Jacket Conference Room. Rotating installations will come over from the Carver Museum to keep the Display active over time.

— Inspire

Eastside ECHS had its own set of challenges from multiple closures, name changes, and relocations. The last relocation was into Johnston HS and did not give Eastside its own identity.

The new modernized campus provided Eastside Early College High School a space designed specifically for their students and faculty. The International school was a partner to Eastside, building language skills and assimilating students into Eastside. The Eastside community is also part of the Anderson history living in the same redline district. The school, alumni, neighborhood, and surrounding community have united around the slogan “**Pride of the Eastside**” and a mission of providing **equitable opportunities and resources for historically marginalized students**.

Pride comes with perseverance and the confidence **to stand up to social injustice, racial division, and economic oppression**. Eastside ECHS also tells their stories, speaking their truth. The echoes the hallways of all three campuses provide a **historical foundation for the next generations** to find strength in the past to propel a future of equality and opportunity.



Project Results

The goal was to provide a custom design solution to preserve the **legacy** of L.C. Anderson while creating a **future ready** school that will propel Eastside Early College High School and International High School students to be career and college ready.

The result is a new community hub worthy of the **Pride of the Eastside.**



“The new Eastside combines the rich history of L.C. Anderson with the bright future of the current generation of students.”

- Andrew Bailey, Eastside ECHS Principal

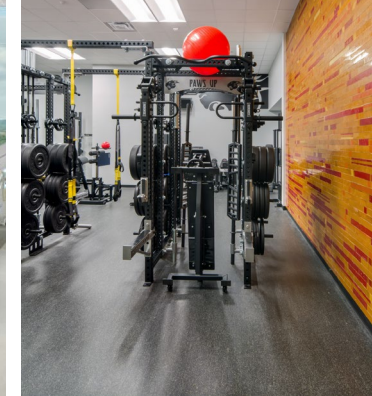

– District Goals

- Build a new campus for Eastside ECHS and International HS at the location of the L.C. Anderson High School
- Construct the district’s first new high school in 25 years while using the district’s new educational specification.
- Create strong community relationships by an inclusive process
- Provide future ready learning for at risk youth
- Expand Early college programs in Allied Health in partnership with Austin Community College
- Maintain the schedule and budget
- Reduce operational costs by sustainable design

– School Goals

- Build a new campus for Eastside ECHS and International HS while not erasing the legacy of the L.C. Anderson High School by reconstruction and salvaged materials
- Design a high school that provides functional equity with the district educational specification and the specific needs of these campuses
- Create strong community relationships by design that is reflective of the community culture and campus stories
- Have flexible and adaptable learning environments that serve the programmatic needs of the campuses
- Support Green Schools Initiative by sustainable design
- Reflect Pride in the Eastside

– Community Goals

- Preserve the legacy of L.C. Anderson High School by reconstructing the memory of parts of the campus
- Provide a Gallery of L.C. Anderson Artifacts
- Tell positive perseverance stories of the African American Eastside Community
- Create community spaces that reinforce this campus as a hub for the community with community amenities, gardens, and uses.
- Provide equitable future ready learning opportunities for Eastside and International students
- Partner with Austin Community College to advance early college credits and no cost associates degrees.
- Embody the Pride of the Eastside

– Unintended Results and Achievements

- In the process of gathering information on the cultural history and legacy, the importance of this site in the East Austin African American community was fully understood. The district, with the support of the alumni, petitioned the state of Texas to provide a historical marker for historic sites.
- The district is also in the process of designating the Yellow Jacket Stadium as a historical site.
- Since the opening of the campus the student population of Eastside Early College has increased by over 200 students as well as a substantial increase in the students participating in the early college programs.