

MADRONA SCHOOL

Edmonds School District
Edmonds, Washington



MADRONA SCHOOL

Through a collaborative, student-led design process it was quickly discovered how designing with equity for continuous growth of all students meant rethinking how spaces foster relationships among students, staff, and parents. As a result, the replacement Madrona School is a richly interwoven, inside/outside quilt of learning that maximizes educational space, communal gathering areas, and connection to the outdoors by minimizing interior circulation. It is a place where student differences are celebrated, respected, and intentionally addressed through design. Through a process of designing for all, Madrona's new home has realized a more acoustic, physical, and gender-inclusive community in which all students feel accepted and connected.

The design of the new Madrona School responds to the unique K-8 Option and North Puget Sound Regional Deaf and Hard of Hearing Programs. Serving 650 students, the new 80,000SF facility engages the school's valued outdoors by embracing exterior circulation as a way to minimize hallways, thus maximizing space for teaching and learning. Each Learning Center, the typical learning setting at Madrona, is designed around flexibility, allowing it to function as one large classroom or two separate but visually connected spaces. The Learning Center is organized to allow 2 teachers, 54 students, and multiple para-educators to gather in the same learning environment. Learning Centers serve cross-age learning and are distributed throughout the site to encourage students of different ages to intermingle and cross paths with one another. The Madrona population refers to themselves as a "Community of Learners," valuing transparency as a way of reinforcing the idea of being together.

Students enrolled at Madrona are placed into tribes at the beginning of their tenure. Tribes are K-8 communities, essentially second families, for the students to be a part of that carry on from one year to the next; adapting only as students graduate and new students enter at Kindergarten. This community-centric, relationship-focused learning model needed to be met with a design that supports this approach and to ensure the community continues to flourish. A student in one Learning Center is able to see through nature into the adjacent Learning Center and beyond, extending the perception of the learning spaces to the outdoors.

MADRONA SCHOOL



SCOPE OF WORK AND BUDGET



| OWNER | SITE AREA | BUILDING AREA | GRADES HOUSED | STUDENT CAPACITY | SQUARE FEET PER PUPIL | OCCUPANCY DATE | CONSTRUCTION COST | CONSTRUCTION COST PER SQUARE FOOT |
|-------------------------|-----------|---------------|---------------|------------------|-----------------------|----------------|--|-----------------------------------|
| Edmonds School District | 14 acres | 80,000 SF | K-8 | 650 | 123 SF | Jan 2019 | Budget: \$35.7 M Final Cost: \$36.2 M | \$450/SF |



| | |
|--------------------|--|
| → OFFICE | RESPONSIBILITY PERFORMANCE KINDNESS EMPATHY RESPECT PERSISTENCE |
| ← COMMONS | RESPONSIBILITY PERFORMANCE KINDNESS EMPATHY RESPECT PERSISTENCE |
| ← DEN | RESPONSIBILITY PERFORMANCE KINDNESS EMPATHY RESPECT PERSISTENCE |
| ← FAMILY ROOM | RESPONSIBILITY PERFORMANCE KINDNESS EMPATHY RESPECT PERSISTENCE |
| ← GYM | RESPONSIBILITY PERFORMANCE KINDNESS EMPATHY RESPECT PERSISTENCE |
| ← LEARNING CENTERS | RESPONSIBILITY PERFORMANCE KINDNESS EMPATHY RESPECT PERSISTENCE |
| ← LIBRARY | RESPONSIBILITY PERFORMANCE KINDNESS EMPATHY RESPECT PERSISTENCE |
| ← MUSIC | RESPONSIBILITY PERFORMANCE KINDNESS EMPATHY RESPECT PERSISTENCE |
| ← TOILET | RESPONSIBILITY PERFORMANCE KINDNESS EMPATHY RESPECT PERSISTENCE |



EVERYONE HAS A SEAT AT THE TABLE

At the center of this educational specification and design process were the Madrona Steering Committee (MSC), tasked with decision making; the Design Review Committee (DRC), tasked with collecting community and user group insights to inform the design; and the Visionaries, tasked with assuring that the project direction was guided by ideals rather than compromises. Student user groups were also held to understand what defines an inspirational learning setting and their ideas were presented to both the MSC and DRC groups.

MADRONA STEERING COMMITTEE The Madrona Steering Committee (MSC) was made up seven Edmonds School District personnel and Madrona administration.

DESIGN REVIEW COMMITTEE The Design Review Committee (DRC) was a 22-person committee comprised of Madrona administration (principal and assistant principal), Deaf and Hard of Hearing (DHH) staff, teachers, students, and parents. This committee had broad-based representation and a regular meeting schedule, both necessary elements for gaining high level insight and successful support for the findings inclusive within the site-specific Educational Specifications.

VISIONARIES The Visionaries were comprised of Madrona administration (principal and assistant principal) and teachers. This group was brought in at key junctures to either enhance and challenge the DRC work or to validate a direction established by the MSC prior to sharing it with the DRC.

STAFF - FOCUS GROUPS Over two separate days, participatory workshops were held with 1-5 staff members to explore specific issues, including instructional methods, learning styles, and other curriculum-related topics, covering every user type at the Madrona School.

STUDENTS - WORKSHOPS Two workshops were held with two sets of 16 students of various ages to discuss what currently works or doesn't work within the existing school and the site, to explore ideas through a photo exercise, and to create ideal outdoor learning/play spaces through a drawing exercise. Results were shared back with the MSC and DRC.

MADRONA SCHOOL

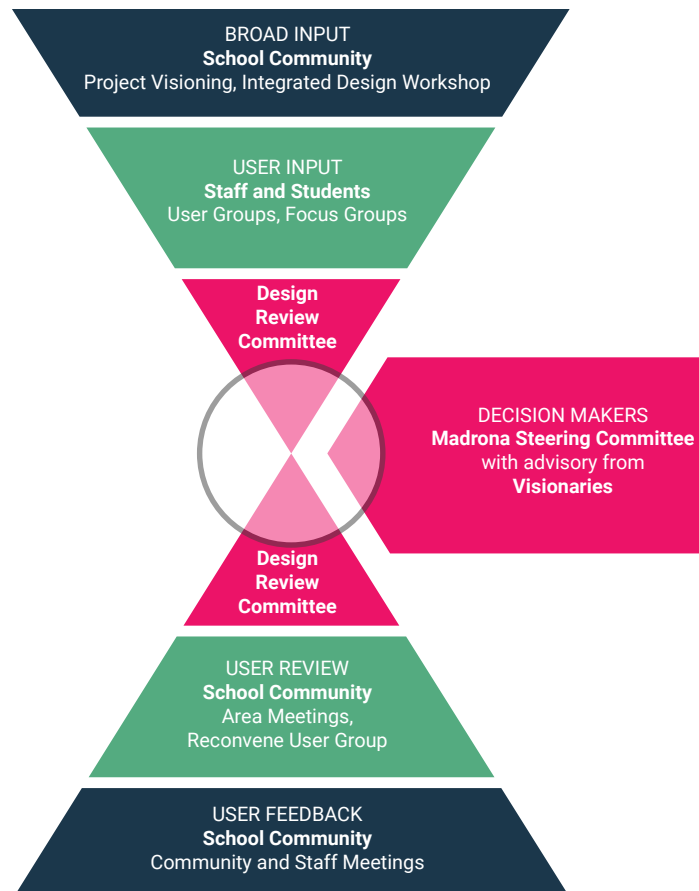

WORKSHOPS AND ACTIVITIES

Together, the district and design team developed an interactive and highly engaged process that layered multiple groups to facilitate a decision-making process where all contributing opinions could be recognized.

SPECTRUM PRIORITIES Working to understand where the community's priorities fell along many spectra, the design team created prioritization questions for the DRC and parents of the Madrona Community to answer along a scale. Through this activity, the participants helped discover Madrona campus' heart, ideal campus organization, and center organization ideal. In addition, the activity revealed areas of consensus or divergence, both of which guided the design team direction.

When asked what the heart of campus should be, a student member of the DRC added the option "**OUTDOOR LEARNING**" as the heart of Madrona. The other participants immediately gravitated toward this theme and it became central to the design concept. Additionally, **COVERED OUTDOOR CIRCULATION** and **K-8 CO-MINGLED** organization became priorities from the onset of the design process.

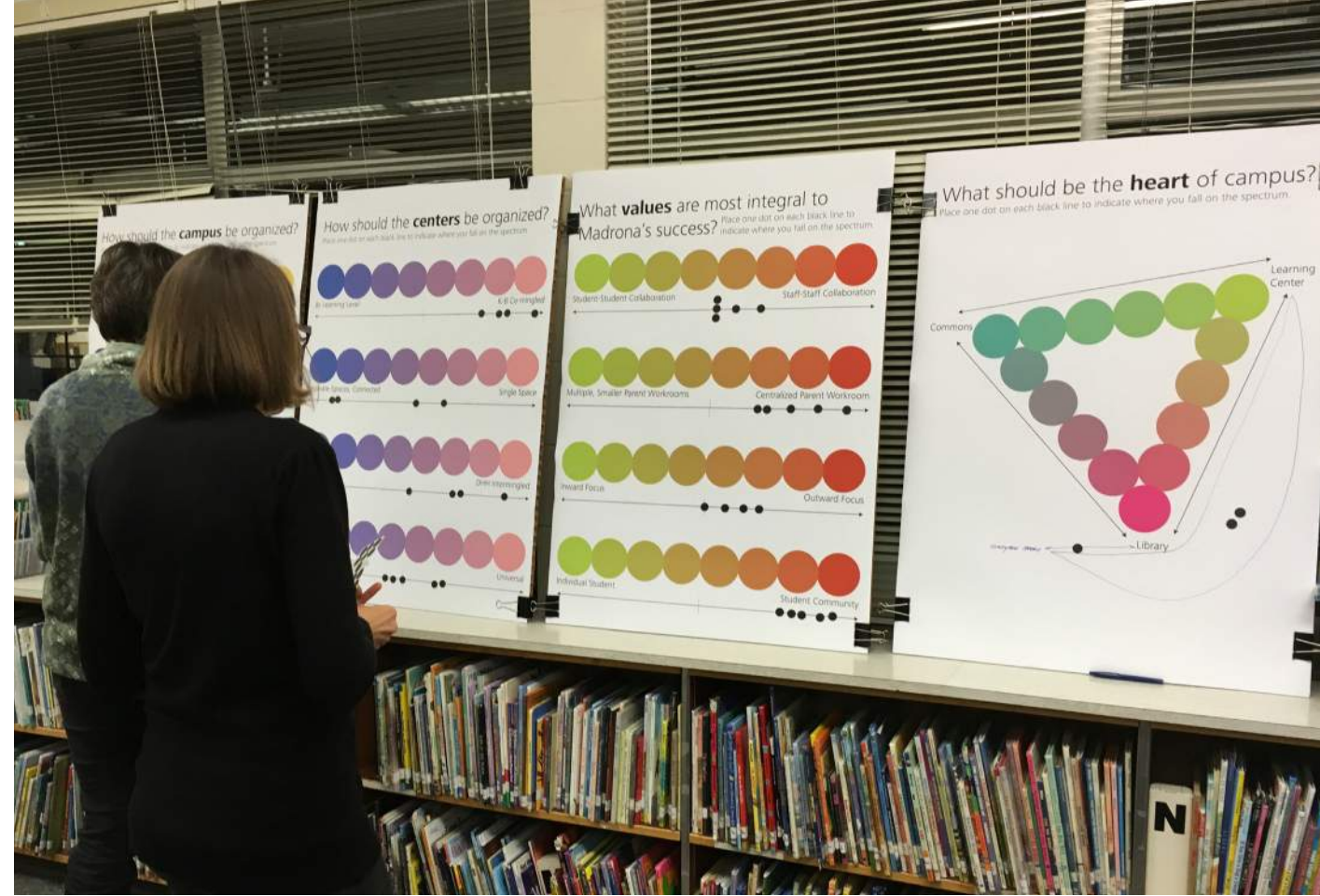

What should be the heart of campus?

Place one dot on each black line to indicate where you fall on the spectrum.

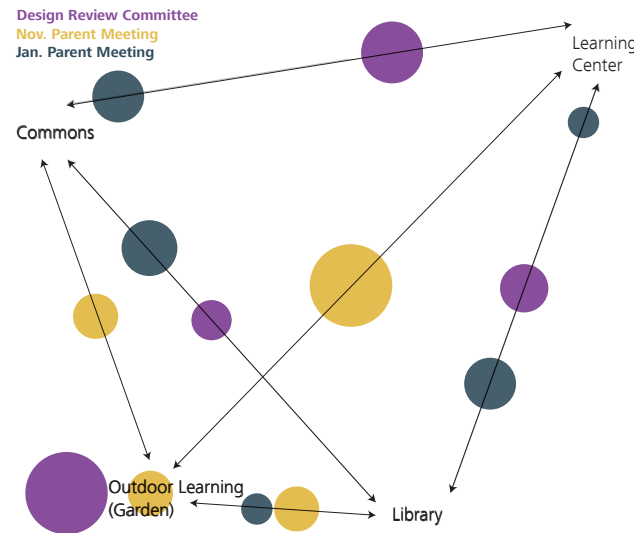

MADRONA SCHOOL

How should the campus be organized?

Place one dot on each black line to indicate where you fall on the spectrum.

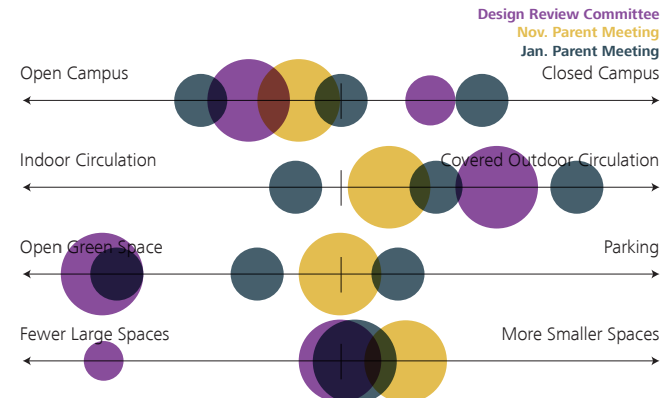

How should the centers be organized?

Place one dot on each black line to indicate where you fall on the spectrum.

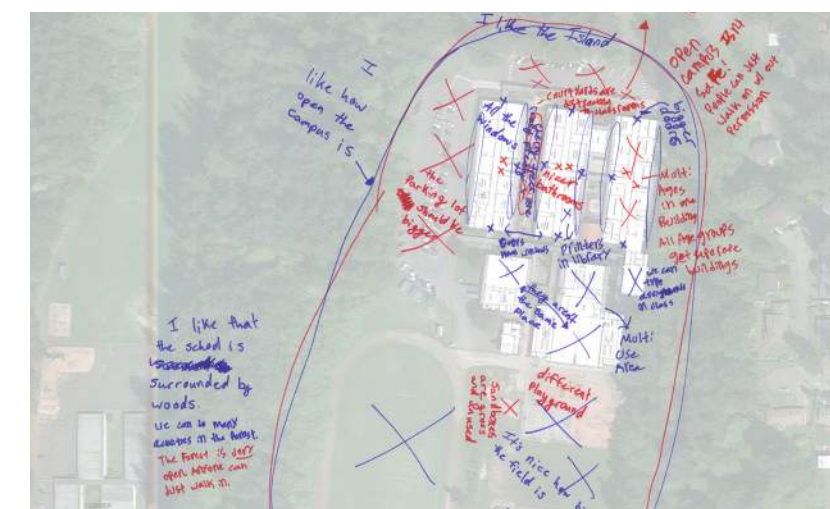
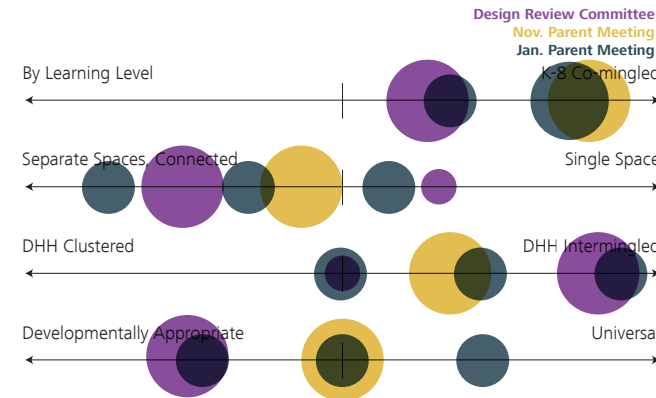

IMPORTANCE OF THE OUTDOORS

The many engagement exercises continually reinforced the value the Madrona community places on outdoor learning and exterior connections.

INSPIRING SPACES TO LEARN - STUDENT OPINION

Students were given disposable cameras and asked to document things that made them happy and feel inspired to learn. The following findings were uncovered on the second workshop when students were asked to share back.

- > 85% of all photos taken were of the outdoors, including all images on the right
- > Student artwork
- > Green spaces
- > Outdoor Play
- > Spaces under natural covering (trees, "the Island," etc)
- > Pathways

WHAT WORKS / WHAT DOESN'T WORK Given plans/maps of the school, students were asked to highlight elements of the school 'that work' in blue ink while issues 'that don't work' with the existing Madrona School design or issues that are not addressed in the current school were to be highlighted in red. The following were the items noted that worked with overwhelming consensus.

WHAT WORKS

- > Outdoor circulation
- > Open campus
- > Surrounded by the woods, including trails for adventure
- > Large field/play
- > "The Island," providing a much-needed nature play break
- > Lots of windows

HEADLINE EXERCISE Parents, at their very first meeting, were given the following prompt:

Madrona K-8 School has been replaced. A reporter from The Daily Herald visits the school to document the new student achievements made possible by the new school.

What do they see and what is the headline of the article in the paper the next day?

Three groups formed to create a headline and describe what they envisioned seeing, giving a measure of success for the design team to strive for. The headlines are below.

KIDS LEARNING INSIDE AND OUT

- > Indoor/Outdoor learning
- > Learning how to interact with others
- > Learning about themselves

MADRONA PUTS ON GRAND OPENING OUTDOOR CONCERT

- > All 650 kids (voices and instruments) entertaining the whole community
- > All kids showing off their learnings
- > The community congregates in outdoor amphitheater

A TRULY COLLABORATIVE, INTEGRATED EXPERIENCE

Students engaged in multiple ways:

- > Televised student Ted Talks
- > Student Living Museum
- > Student activism/community/global service
- > Students collectively reducing waste
- > Students teaching parents about sustainability
- > True and fluid interactions among K-8



LEARNING CENTER PRIORITIES

FUNCTIONAL PROGRAMMING The design team led the DRC through a functional programming exercise intended to garner information to program the facility around teaching and learning activities rather than around the traditional method of number of students in a classroom, or Learning Center. The committee was asked to work collaboratively to: first identify ideal group sizes for each highlighted learning activity; second identify tools needed to accomplish the learning activity; third to determine which learning activities best support different age bands, such as primary or middle school, or content areas, such as science or art. This activity informed how the Madrona Community needed the new building to function for learning while also meeting the capacity needs. In addition, this activity generated spatial requirements for the Learning Centers resulting in a variety of spaces for collaborative learning size, configuration, and function.

With a focus on activities, group size and frequency, rather than numeric program spaces, the functional programming exercise uncovered that ideally teaching and learning environments at Madrona School would accommodate large group activities (groups of 27+ students) 30% of the time, while 70% of the time, small group, project based activities occur within groups of 14 or less.

It is important to note that these functional program findings suggest that even through the overall vision of full-center learning at Madrona: 54 students and multiple adults gathered together in morning-greeting circle or in share-back presentations, the majority of the time requires learning settings in groups less than 14.

Additional analysis of the programming activity also suggested that group size requirements differed amongst age groups.

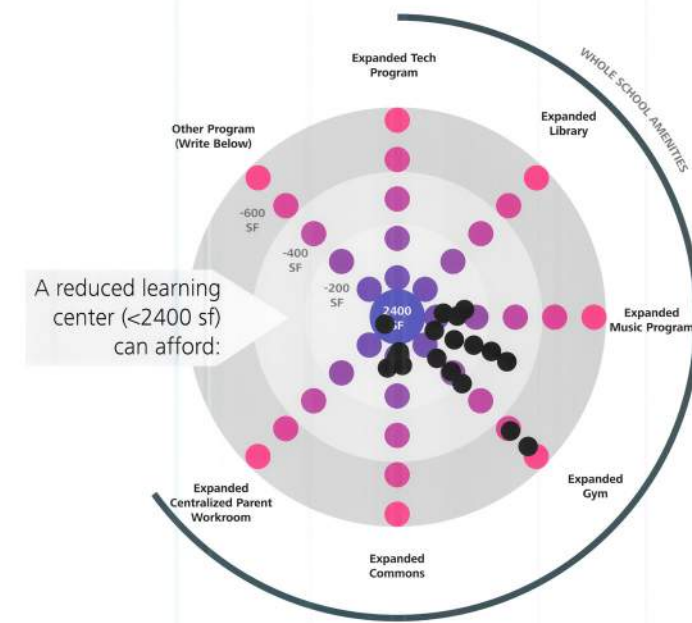
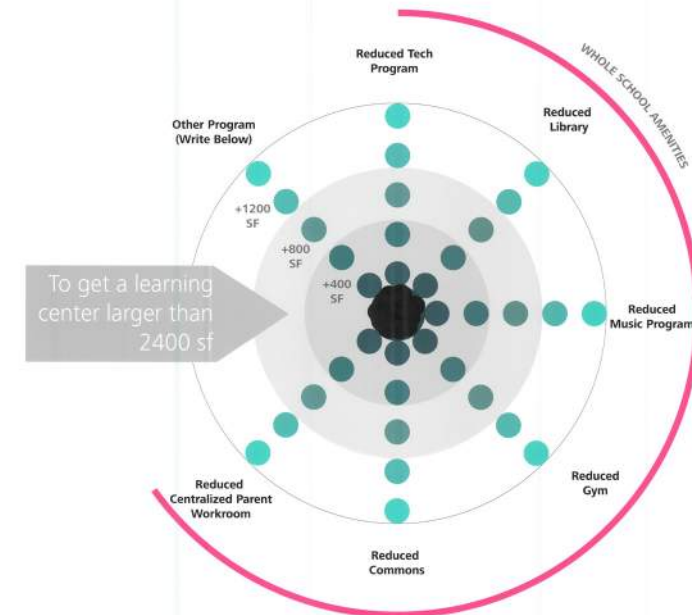
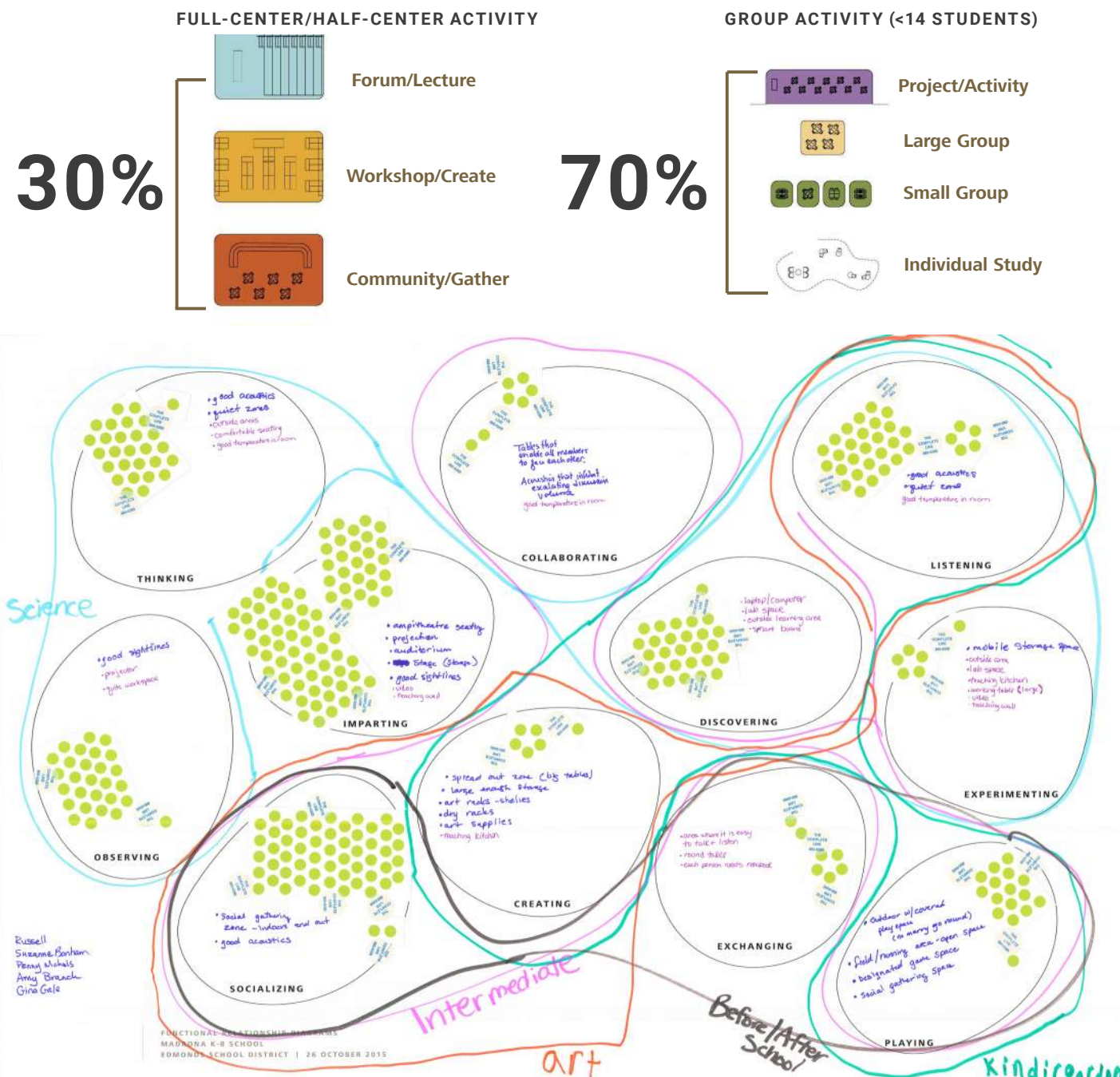

SPACE ALLOCATED FOR THE LEARNING CENTER
When asked, "**WHAT ARE YOU WILLING TO COMPROMISE FOR AN EXPANDED LEARNING CENTER?**", DRC members prioritized the square footage of the Learning Centers above all allowing for the larger space allocation. Each Learning Center is programmed at 2,400 square feet to provide adequate space to achieve full-center learning with 54 students as well as small-group activities. This was accomplished through significant flexibility (moving walls, glass partitions, furniture, moving technology, etc).

SPATIALIZATION OF THE LEARNING CENTER

LEARNING CENTER PROGRAM DIAGRAMS Following the strong feedback that each Learning Center should be both developmentally appropriate (i.e. different at each age band) and contain the entirety of its own learning spaces, the design team began to investigate how large each Learning Center would need to be and the way in which each should be composed.

An exercise was developed to help the DRC understand the opportunities inherent in various arrangements of teaching spaces, allowing each participant to choose cards representing different sized spaces with the overall target of understanding if the 2400 SF allocated was sufficient. Groups were organized by age band, to further highlight what, if any, differentiation there may be between age groups – kindergarten, primary, intermediate, middle. Spaces available were all pulled from prior discussions and included 150 SF small group or storage, 300 SF large group or storage, 600 SF half-center learning, 900 SF half-center learning, 1200 full-center learning, and 1800 SF full-center learning.

This activity not only generated a variety of learning center arrangements, each with unique potential for teaching and gathering, but it ALSO reinforced the previous preference for developmentally appropriate learning spaces over universal. The design team recognized from this exercise that the Learning Center would be required to be adaptive and able to accommodate a variety of learning setting styles.



AGE APPROPRIATE AND EQUITABLE LEARNING CENTERS

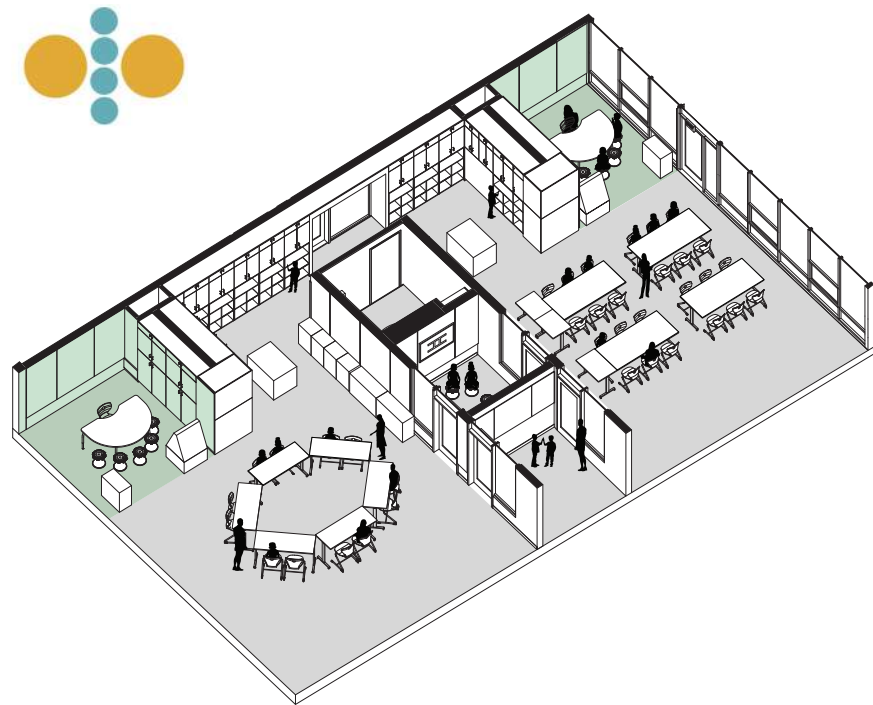

KINDERGARTEN As children entering school for the first time, Kindergartners at Madrona are not integrated into cross-age learning yet to allow them to get them accustomed to the culture of school. To accommodate many more small group activities than Primary- and Intermediate-age learning, the teaching spaces are divided with additional small group areas for 5-6 students and a larger, accessible restroom. The main teaching space is sized to fit a group of 22 students sitting in a circle.

Storage and individual student cubbies line the back wall where access to the main Kindergarten Learning Center toilets and sinks are able to be supervised from the Learning Center. The centrally located storage allows (2) teachers to share materials, previously requiring duplicates, while providing easy access from the learning space.

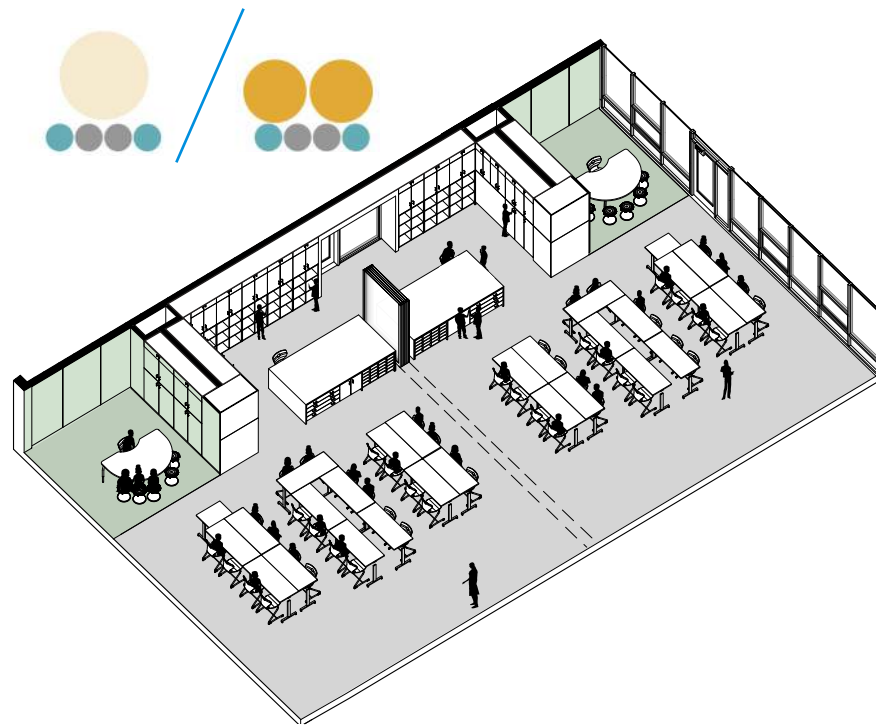

PRIMARY / INTERMEDIATE Allowing team-teaching of 54 students total, Primary (consisting of grades 1-3) and Intermediate (consisting of grades 4-6) centers are designed to have the flexibility from a 54-student learning space to (2) separate learning spaces that can hold 20-30 students for developmental-based learning. This is achieved by simply opening the center sliding glass door. Small group nooks within the Learning Centers provide small group or individual work spaces, separate from the larger group.

Storage and individual student cubbies line the back wall where access to shared inclusive toilets and sinks are able to be supervised from the Learning Centers.

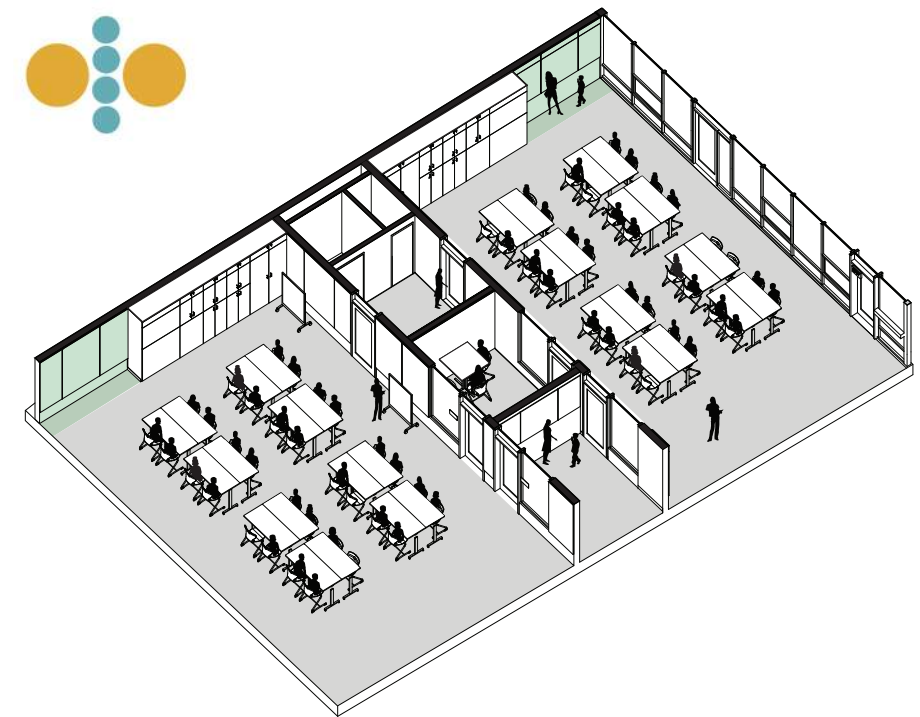

PRIMARY / INTERMEDIATE DHH Designed for a maximum of 13 students, 1 teacher and 3 para-educators or interpreters, the DHH Learning Center shares 2 enclosed small group rooms accessible to either Primary or Intermediate teaching space. The main teaching space is then kept open and flexible to meet the needs of the DHH population and the additional support staff integral in the DHH program.

MIDDLE SCHOOL Designed in pairs, the Middle School Learning Centers are configured like the Primary/Intermediate DHH Learning Center with 2 teaching spaces sharing two small group rooms and toilets, accessed from both sides. Each Learning Center serves 32 students and 1 teacher. Students in Middle School travel between classes multiple times a day, therefore the location of the Middle School Learning Centers is critical to reduce noise distractions in the Kindergarten, Primary, and Intermediate classes.

LEARNING CENTER FLEXIBILITY

The primary and intermediate education programs at Madrona, for learners in grades 1-6, balance team teaching of 54 students within one Learning Center with developmentally-appropriate teaching of 20-30 students for the remainder of the daily teaching. By creating a single 2,400 square foot space with an operable, transparent wall and small nooks for small group activities, a variety of learning styles can be met. When the operable wall is deployed, the importance of the whole Learning Center and the feeling of "togetherness," no matter the teaching style, required the sliding wall to be transparent above 42". This configuration allows for an environment that is able to evolve and be responsive to student needs today and in the future.

Throughout the design process, it was important that the Option Program-specific Learning Centers would be able to return to a familiar classroom model. If the district ever needed the new Madrona School to serve a typical 900 square foot, 1 teacher and 27 student classroom, each Learning Center variation can be altered to accommodate that program adjustment. Careful consideration was given to the fixed building systems (wall, hvac, power and data) to allow for this potential transformation over the life of the school. Each Learning Center, symmetrical about the dividing wall or small group/restroom core, could be easily divided for a standard teaching/learning program.

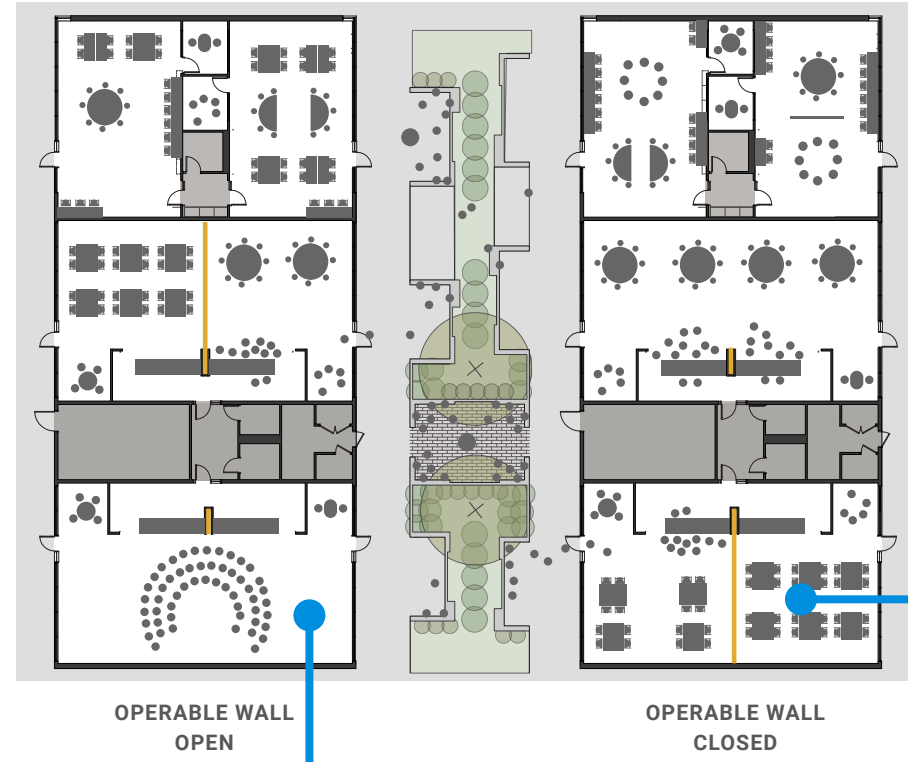

FLOOR PLAN

DEN "The Problem Solving Solution Space" at Madrona, known to students as a neutral ground that can be utilized for alternative recess and quiet self-reflection space

DHH Deaf and Hard of Hearing-specific Learning Centers

LS Learning Support

MIT "Madrona Integrated Team," the parent volunteer contingent, instrumental in creating the community culture of the educational program alongside the teachers



QUILT OF LEARNING

INDOOR & OUTDOOR LEARNING

Each student in the Learning Centers is able to see through nature into the adjacent Learning Center and beyond, extending the perception of the learning spaces to the outdoors. The direct flow of spaces from the Learning Centers through the Exploration Porches to the courtyards provides every student, no matter age, with direct access to a wide variety of spaces to best support the full spectrum of learning activities necessary for ability based, differentiated learning.

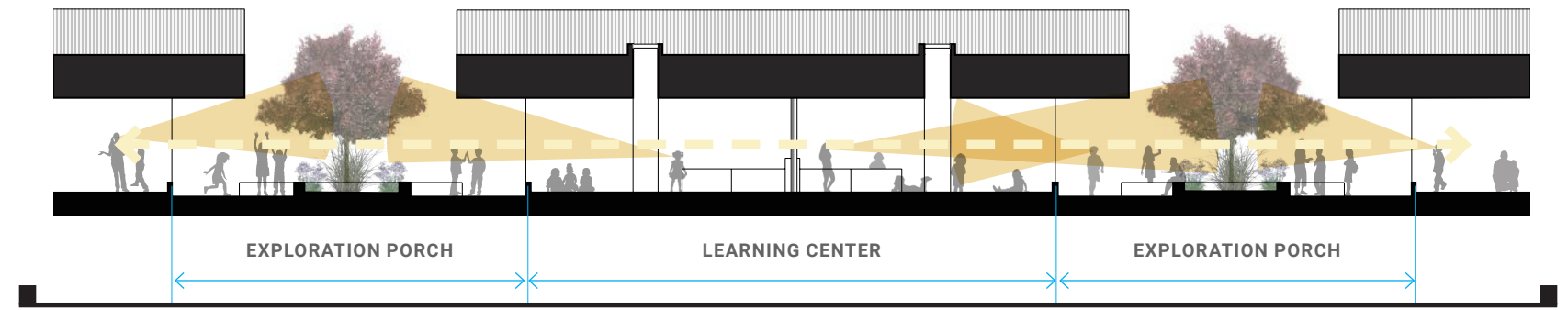

- Kindergarten Learning Center
- Primary Learning Center
- Intermediate Learning Center
- Middle School Learning Center
- Outdoor Learning





SUSTAINABILITY

When asked what is the heart of Madrona, the Madrona community responded with their own unique answer: Outdoor Learning. With this in mind, the DRC described one of their top five priorities "to create an aesthetically beautiful facility that nourishes the whole person, while respecting the environment through the use of natural materials and resources."

As a single story building, each Learning Center has a direct relationship to outdoor learning. Exploration porches open up to the broader site, including the ravine to the east and the track and playground to the west. Addressing mindfulness, the building explores ways of facilitating an awareness for the natural environment and others. The water cycle is celebrated inside and outside of the building, and rain events are highlighted through roof drainage into the rain gardens, adjacent to the main exterior circulation spine.

Mechanically, radiant floors, an air source heat pump, and heat recovery ventilation contribute to exceptional occupant comfort and reduced energy use. Spaces are designed to support a culture that requires a sensitivity to glare, with daylight abundant through vision glazing under deep overhangs and skylights located in the middle of the Learning Centers.

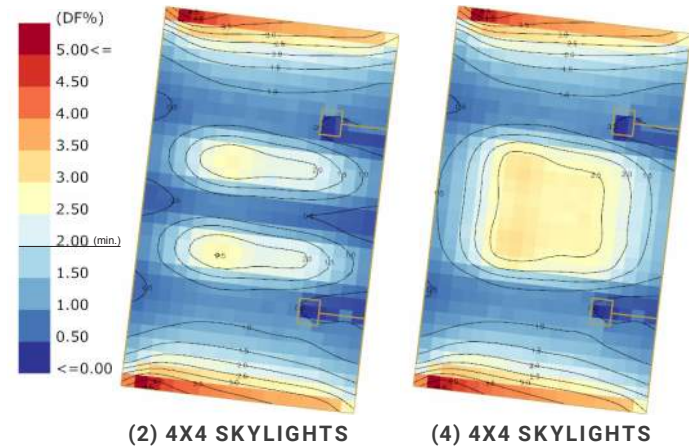

MADRONA SCHOOL



DESIGNING FOR DEAF AND HARD OF HEARING

Madrona's supportive learning environments provide quality education to students who use sign language from ages 3-14 for Edmonds School District's Regional Deaf and Hard of Hearing Program. Currently serving 60 DHH students from 26 different school districts north, east, and west of Seattle, it is critical that the new Madrona school contributes to positive qualities of learning environments for all and responds to specific acoustic and spatial needs of learners who do not rely on audio-input.

Leveraging DeafSpace Design Guidelines, numerous design strategies support the unique needs of students' hearing differences and create a more equitable learning environment. These include appropriate **CEILING AND WALL ABSORPTION** throughout the school, extensive **TRANSPARENCY** across spaces to avoid hidden corners so that students and staff can see around them, **WIDER CIRCULATION PATHS** that enable students to converse in American Sign Language (ASL) while walking side-by-side, and the selection of **SPECIFIC COLORS THAT CONTRAST** for legible signing. Reducing glare and utilizing the correct lighting was also a key factor in reducing eye strain and providing a successful space for DHH students and staff.

Additional technology is integrated in the new Madrona to facilitate communication with all students and staff concurrent with messaging delivered via the intercom system. Colored strobes to provide emergency and operational notification are included as well as additional large format displays and reader-boards located at interior and exterior locations to allow legible text to scroll through announcements.

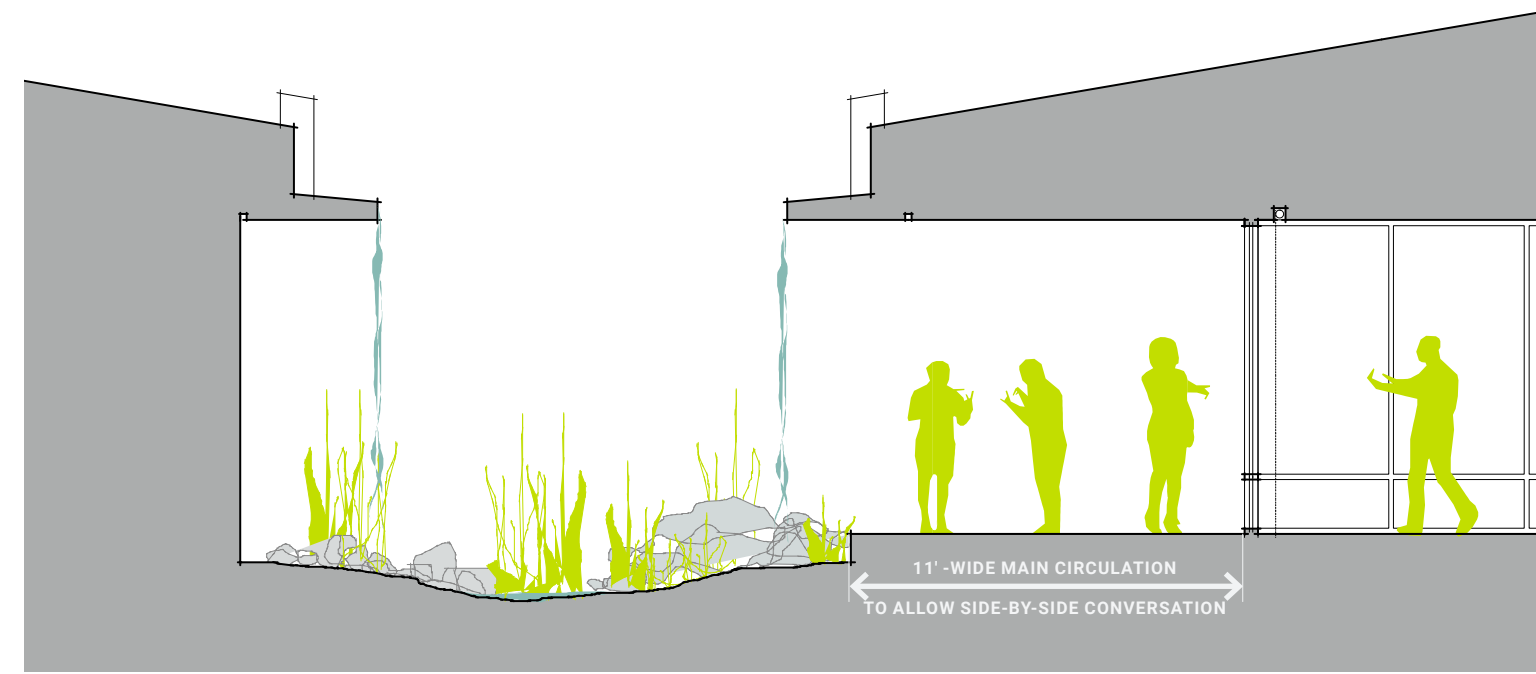
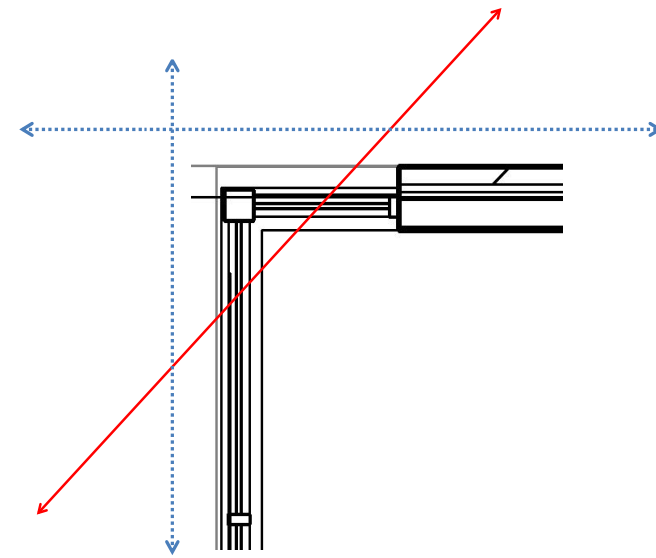

SECURE PERIMETER

MADRONA COMMUNITY'S PERCEPTION OF SAFETY

Particular attention has been given to security, with entry limited to a single point at the front of the school. The open courtyards at the learning gardens are secured with decorative fencing and gates. While fencing provides a direct barrier, the transparency of the building and fence encourages the users through passive supervision to keep watch on their surroundings and take part in the safety of their school.

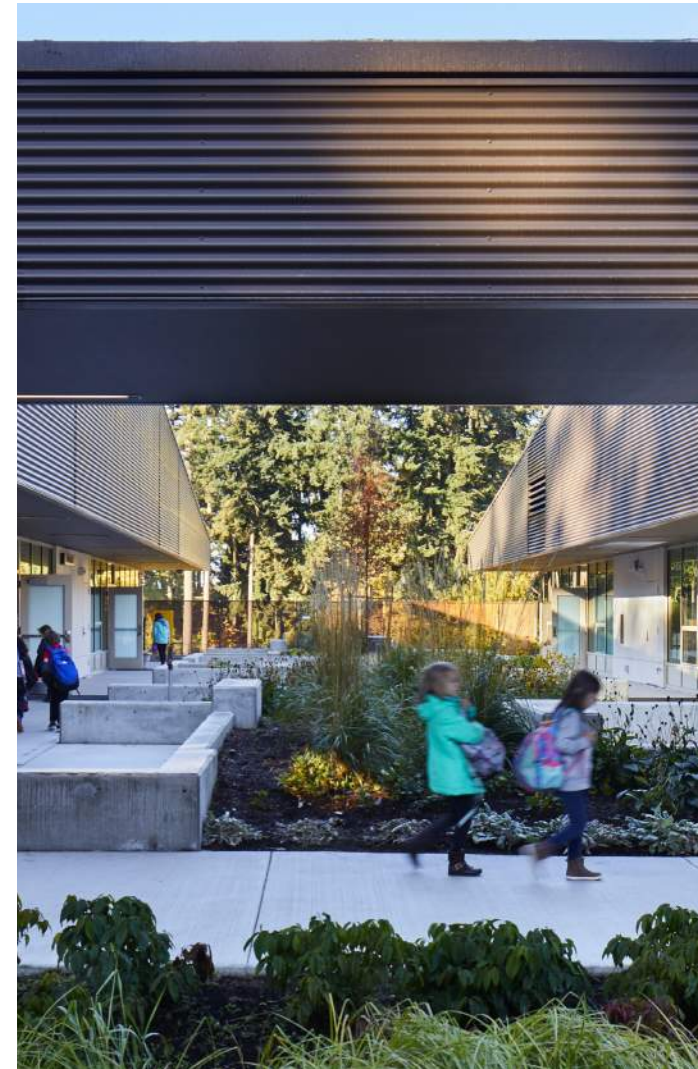

MADRONA SCHOOL

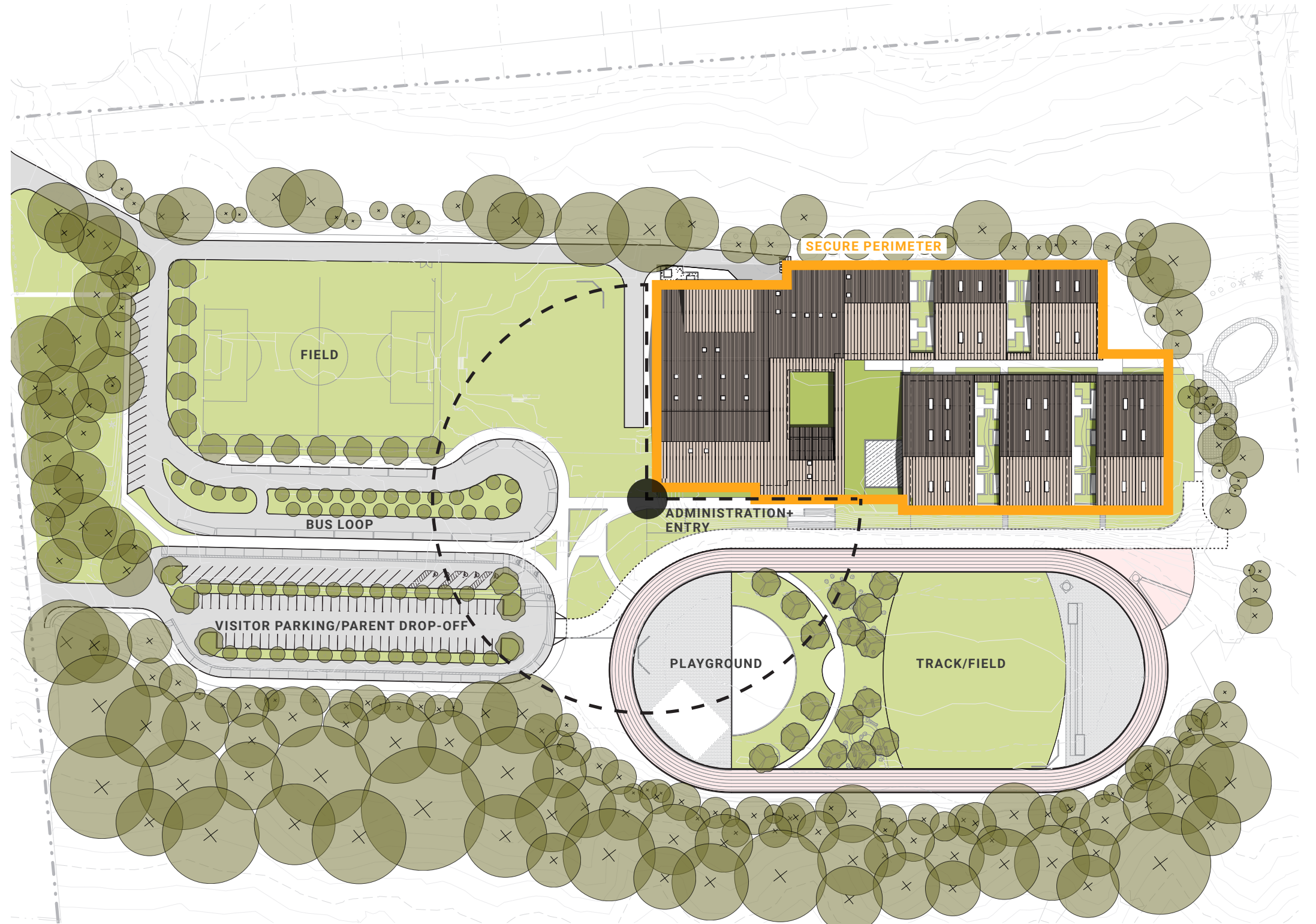

RESPECT AND OWNERSHIP

STUDENT GENERATED GRAPHICS As a school community, Madrona students and staff identified 13 attributes of character to focus on for growth and development as part of every school day (Respect, Responsibility, Kindness, Patience, Empathy, Gratitude, Perseverance, Courage, Forgiveness, Self-Discipline, and Service). The students were asked to choose the attribute that resonated with them most and handwrite that word to be etched into the entry wall, giving a sense of pride and ownership to the students.

Additionally, the connection to trees and nature was celebrated again by encouraging each student, parent, and community member to participate in the hand-drawn leaf explosion that, only when placed together, create the "MADRONA" community pride graphic.

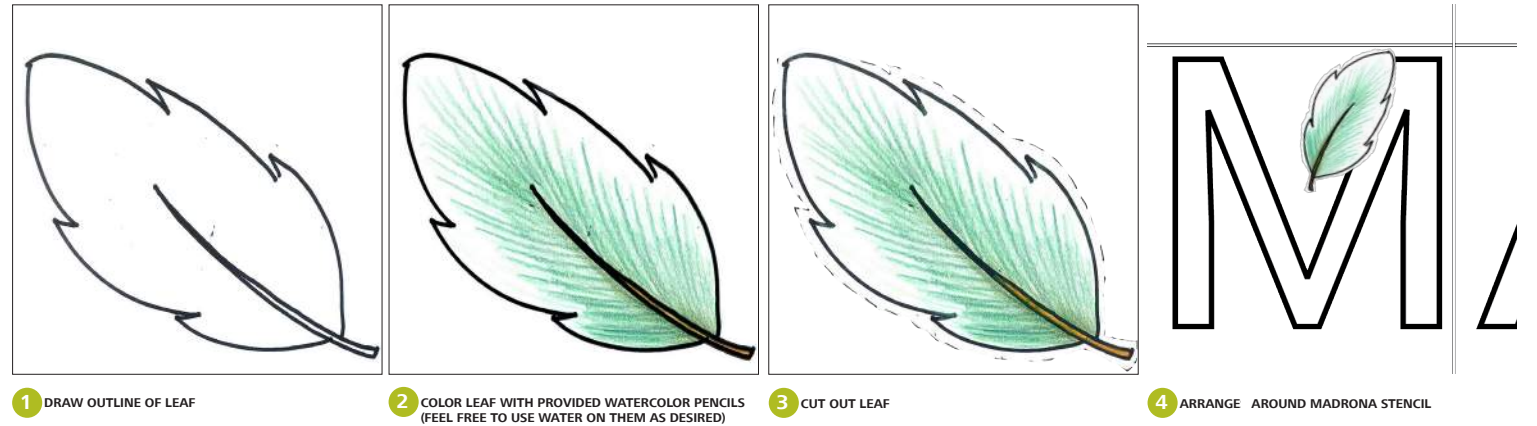

MADRONA SCHOOL



RE-IMAGINING RESTROOMS FOR ALL

Placing equity and human dignity at the center of design conversations, the Madrona community prioritized a toileting solution that removes the need for students and community to associate themselves with a male/female or disability label when choosing a restroom.

GROUP RESTROOMS To address bullying and the perceived lack of safety in typical restroom configurations, the design replaced existing gendered, group restrooms with 100% individual toilet rooms. Full walls and full doors open to a shared space with handwash stations and drinking fountains. In addition, as a pass-through space with multiple ways in and out, the design limits entrapment and allows for passive supervision. Urinals were not installed, eliminating gender specific fixtures. Additionally, the restrooms signage removed any reference to gender and are signed with a simple pictorial representation of a toilet indicating it is for use by all.

Throughout the planning process, the public group restrooms were designed to be able to revert back to "gendered" restrooms if either the community or district were not comfortable with the results, especially in relation to safety and security. The separation wall was not built and is not planned to be installed.

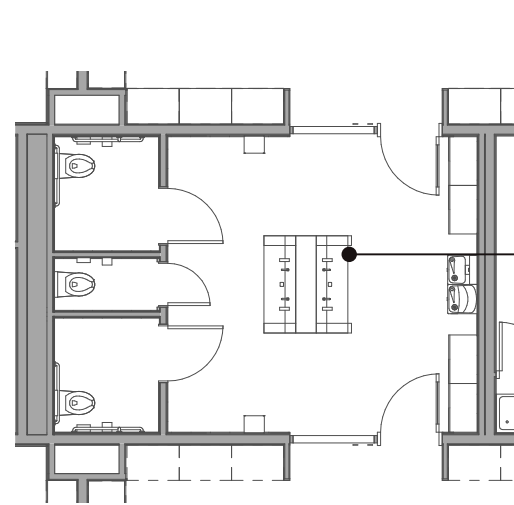

LEARNING CENTER TOILETS

TRANSPARENCY ALLOWS FOR SUPERVISION FROM LEARNING CENTERS TO HANDWASHING

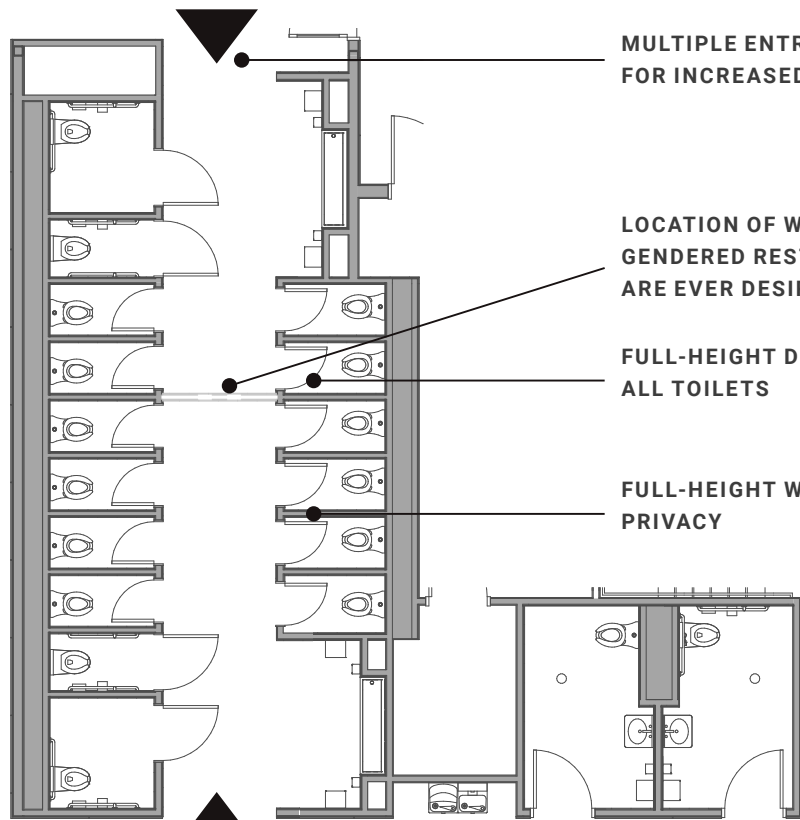
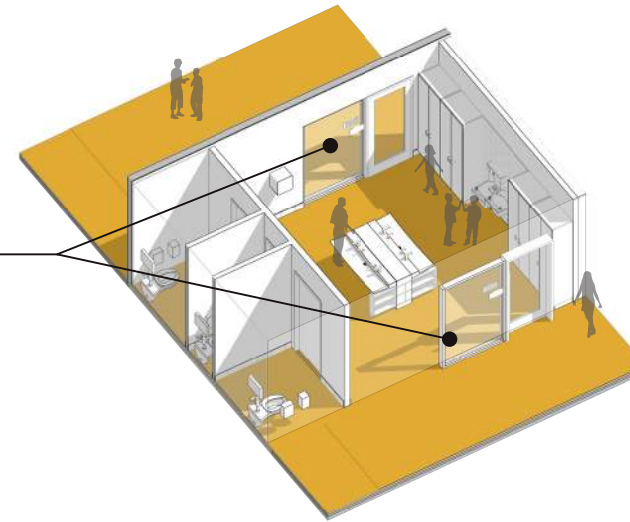

PUBLIC CORE TOILETS

MULTIPLE ENTRIES ALLOW FOR INCREASED VISIBILITY

LOCATION OF WALL IF GENDERED RESTROOMS ARE EVER DESIRED

FULL-HEIGHT DOORS AT ALL TOILETS

FULL-HEIGHT WALLS FOR PRIVACY

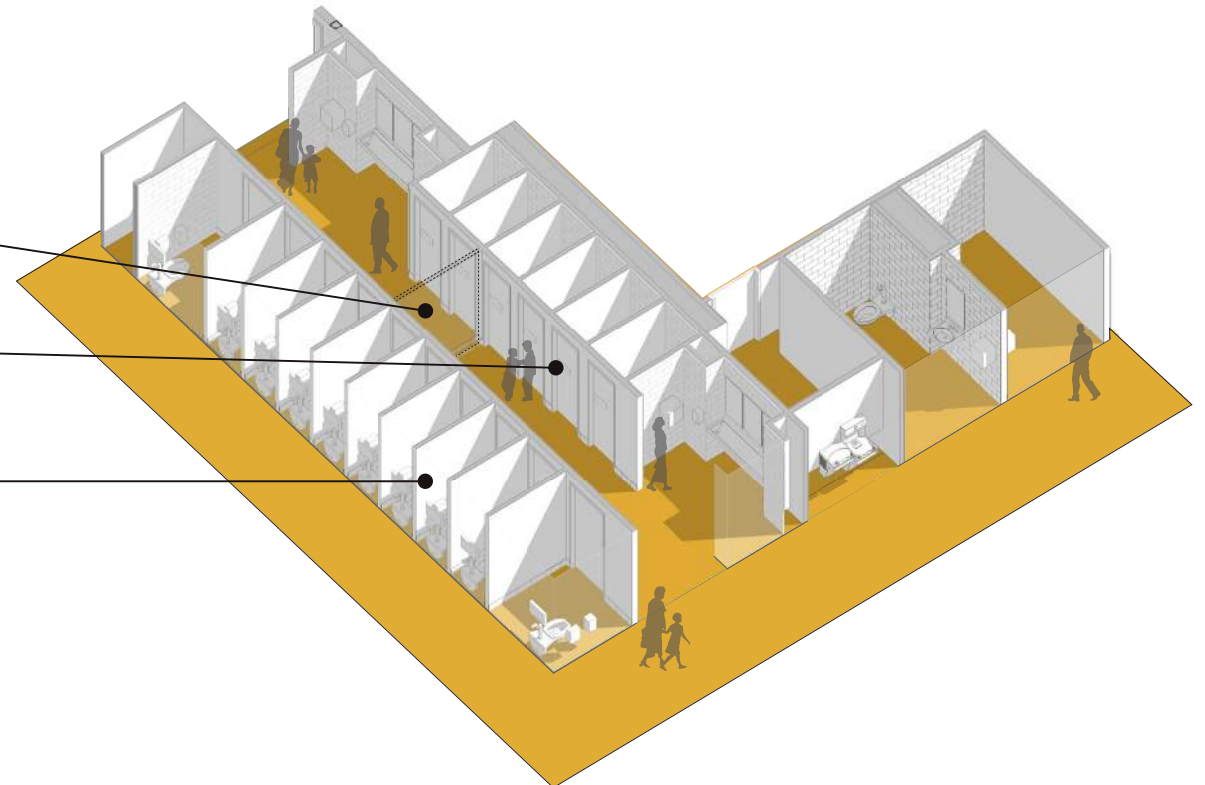

CONNECTED

TO THE EDUCATIONAL PROGRAM

The new Madrona School now serves the unique educational program as the established culture, learning centers and teaching styles informed the ultimate design. From the district's original vision that Madrona's new school would be a two-story building with a small footprint, this completely different outcome of a single-story building with covered walkways and courtyards connecting the learning centers meets the goals of the school and district by strengthening the cross-age learning environment.

TO THE OUTDOORS

One teacher simply put, "**THE NEW MADRONA SCHOOL IS WRAPPED AND HUGGED BY THE SURROUNDING TREES.**" Teachers have discovered the exploration porches to be wonderful resources and an extension of the classroom. Even equipped with wifi, the covered walkways allow for outdoor learning to take place no matter the weather. With increased vision glazing throughout the building and skylights in every learning center, the building provides an abundance of daylight with views through the Learning Centers and skylights to the trees and sky beyond.

TO THE USER

Moving from the notion that the child should fit the school to a notion that **THE SCHOOL SHOULD FIT THE CHILD.** By designing for DHH students to be able to thrive at all grade levels in each learning space, the desire to provide an appropriate learning setting for this community promotes equitable access to education for all students.



